

# InPhase: Evaluation of a Communication System Focused on “Happy Coincidences” of Daily Behaviors

Hitomi Tsujita<sup>1</sup>, Koji Tsukada<sup>2</sup>, Siio Itiro<sup>1</sup>

<sup>1</sup>Graduate School of Humanities and Sciences, <sup>2</sup>Academic Production,  
Ochanomizu University  
2-1-1 Otsuka, Bunkyo-ku, Tokyo 112-8610, Japan  
{tsujita, tsuka, siio}@acm.org

## ABSTRACT

To supplement existing forms of communication such as telephone and e-mail, this research proposes a new method of communicating “awareness” between people who are separated by long distances. In this paper, we investigate cases where coincidences in daily activities lead to casual conversation and thus intimacy and togetherness. We propose a new method of communicating these “happy coincidences” between a pair of remotely located locations. By equipping furniture and appliances such as doors, sofas, refrigerators and televisions with sensors, we developed a system wherein these items are connected to remote equivalents and their near simultaneous use is communicated. We conducted a two month field test of the system in a laboratory setting and a three month field test in an actual home. The study showed that the participant felt the presence of other people and thought about, imagined or even confirmed the habits of others by intentionally triggering the coincidence notification.

## Author Keywords

Coincidences, Awareness, Communication, Synchronization.

## ACM Classification Keywords

H5.m. Information interfaces and presentation (e.g., HCI): Miscellaneous.

## General Terms

Design, Human Factors

## INTRODUCTION

In order to facilitate successful relationships, people adjust their behavior to others around them by imitating each other’s actions unconsciously. In psychology, this behavior is known as “Conformity effects” or mirroring [3]. This action also creates a greater sense of intimacy and closeness for the other. If one wants to create a bond with another

person, imitating what the other is doing (e.g., taking a drink of water together) is effective in creating a connection. We all experience this in our daily lives - when a friend or partner shares a behavior, such as watching the same TV program, this leads to conversation or intimacy. In this way, we feel that “coincident daily behaviors” are a very important factor for our personal relationships to succeed. However, we can only experience some types of “coincident daily behavior” when we happen to be in the same location at the same time. Thus, people living apart, such as family, friends or couples, only find out later if at all and most people living apart never experience this level of intimacy. In order to address this issue, we propose a new system to facilitate remote “awareness” by communicating the occurrence of simultaneous and similar actions of two parties, thus, prompting traditional forms of contact such as a telephone call or e-mail.

## DESIGN AND USAGE SCENARIOS

In this paper, we investigate the daily lives of people by measuring when similar actions of two people in different locations happen simultaneously and use this information to develop an “InPhase” system that can notify them of these coincidences through cues in their environment. For example, as seen in Fig. 1, families or couples living apart have their doors connected to sensors which will sound a chime if both doors are opened at the same time.

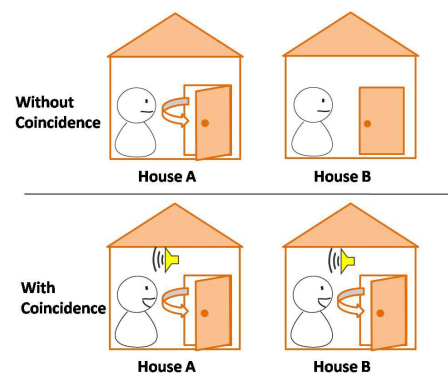

Figure 1. InPhase concept

The InPhase system is an ambient indicator that will notify two remote users when, for example, they are both opening

Permission to make digital or hard copies of all or part of this work for personal or classroom use is granted without fee provided that copies are not made or distributed for profit or commercial advantage and that copies bear this notice and the full citation on the first page. To copy otherwise, or republish, to post on servers or to redistribute to lists, requires prior specific permission and/or a fee.

CHI 2010, April 10–15, 2010, Atlanta, Georgia, USA.

Copyright 2010 ACM 978-1-60558-929-9/10/04....\$10.00.

doors, windows or curtains, watching the same TV channel, sitting on a sofa, or in the kitchen at the same time. When this system is utilized, the following scenarios can be envisioned.

Scenario 1: A husband posted away from his family and living apart from them, wakes up in the morning and opens the window. Coincidentally, the wife, in a different city, also opens the window of her home. At this time, a chime sounds and both people know that they opened the window “together”. Both feel as if they are under the same roof and are happier. Afterwards, the wife sends her husband an e-mail asking “Did you just wake up? Isn’t the weather nice?”

Scenario 2: Two romantically involved people realize that they are watching the same TV program at the same time when the systems chime sounds. At this point, the girlfriend sends a text mentioning how nice the scene on the TV was. The boyfriend replies with a message mentioning that they should go to the place mentioned in the TV show - thereby, encouraging conversation between the couple.

### THE MERITS OF THE SYSTEM

As mentioned above, with this system, it becomes possible to learn when similar actions happen during normal day-to-day activities, thus enhancing intimacy and closeness and potentially prompting other forms of communication. Furthermore, when considering systems that transmit daily actions remotely, our system has two distinct advantages.

First, in a system that continually transmits actions, the persons on the receiving end may be disturbed when they are sleeping or annoyed when they are working [26]. In our system, information about one another’s actions is only transmitted when the actions are synchronized. Therefore, there is a certain expectation on the receiving end about an action when they are also doing the same thing, thereby reducing the general annoyance towards the system. People may feel that they are being spied on when a system transmits more information on daily activities than is received from others.

The second advantage of this system is that it is fair and minimizes privacy concerns, because the amount of the information sent to both parties is exactly the same. For example, one party may not want the other to know which TV program he/she is watching. However, when the couple is watching the same program, this fact could probably be shared.

### CLASSIFYING COINCIDENCES

There are many ways to define how the system senses a person’s action. Additionally, there are actions that are unlikely to coincide very often. For example, watching the same TV program in each house may happen with high frequency, but the simultaneous opening and closing of the refrigerator door is considerably less frequent.

In determining “frequency of coincidences”, i.e. the number of times that two remote actions happen simultaneously per

day, there are two factors. They are the number of actions that happen in one day, and the length of time that an action takes. Figure 2 shows some daily actions and behaviors mapped over the two factors. The example P (an action that occurs with high frequency but of short duration) and Q (an action that occurs with low frequency, but of long duration) might have the same frequency of coincidences.

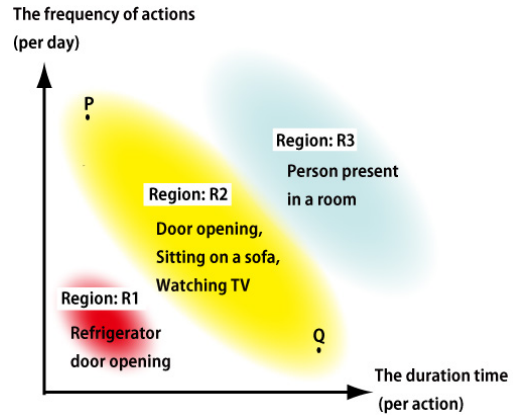

Figure 2. Classification of coincidences based on frequency and duration.

Depending on the frequency of coincidences, a user will have varying degrees of interest towards it. For example, a coincidence that occurs too often may eventually irritate the user. Conversely, a coincidence that happens infrequently may not enhance communication. Either case would result in sub-optimal acceptance of the system.

Therefore, we assumed that coincidences which occur at about 1-2 times per day would be a reasonable level for user expectation and thus user happiness. In our system, we aimed for a system design which notified of coincidences 1-2 times per day.

As seen in Fig. 2, we grouped actions by the frequency of coincidences. In region R2, we define the group of actions where a coincidence happens around 1-2 times per day. In region R1, we defined the group where coincidences occur less than R2 or about 0.3 times per day. Finally, in region R3, we define the group where a coincidence occurs more than twice per day.

Furthermore, while we aim to notify the user of coincidences classified in R2, we believe there are two methods where the system could appropriately notify the users of coincidences classified in regions R1 and R3.

In the first method, we propose changing the sound of the chime depending on the frequency of coincidences in that region. For example, in a lower frequency coincidence such as in R1, we can play a tune for a longer duration. Conversely, for the highest frequency of coincidences found in R3, we would want to produce something that is not disturbing to the receiving party. For example, it is possible to use lights or actuators (instead of sounds) to notify the receiving party.

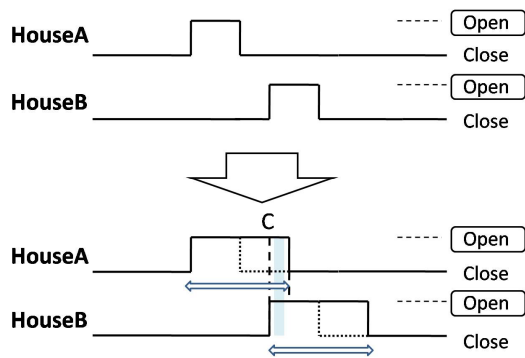

**Figure 3. The upper timing chart shows open/close event of doors. The lower is a result of adjustment of duration time. The system indicates the coincidence at “C.”**

In the second method, there is also a possibility that the system could adjust how coincidences are calculated. For example, as shown in Fig. 3, when detecting the opening and closing of a door in each house, the frequency of coincidences would be very low due to the short duration of the action. The frequency of coincidences may increase if the signal is extended a few seconds longer than the actual close time. Conversely, it might be important to eliminate short duration inputs with high frequency of occurrence. For example, it may be appropriate to eliminate frequent sitting and standing events during dinner or input from the TV remote control while channel surfing. However, if the system decreases the events too much, it may reduce the effectiveness of the system. More research is needed to determine the appropriate adjustments.

### IMPLEMENTATION

Among many kinds of daily activities, we selected events with different frequencies and durations. Although lifestyle and family composition would affect these factors, we made general assumptions based on the author’s lifestyle. The selected events were expected to trigger other forms of communication such as phone calls, e-mail, and on-line chat. The following describes each in-depth.

The first event we have chosen is to determine if person is present in a common space (e.g., living room) by placing a pyroelectric infrared motion sensor in the corner of a room. A living room will be used often for a longer period of time, thus this event falls into R3 category per Fig. 2. When people are present in both remote rooms, the system will play a pleasant natural sound. For the second event, we chose a sofa, wired with three separate pressure sensors placed under the cushions (Fig. 4), where the usage rate is lower and occurs for a shorter duration – R2 category. When there is simultaneous use of sofas in both locations, the system plays a chime sound. The living room door opening is selected as a third event. While the door has a high frequency of usage, the event itself is very short and therefore this event is in the R2 category where the system will play a chime sound. A refrigerator door opening is chosen as the fourth event. The refrigerator has a low

frequency of usage as well as a very short duration putting it in the R1 category where the system will play a trumpet sound. Both the door and the refrigerator door are fitted with a magnetic reed switch (Fig. 5). The fifth event is watching the same TV program. For detecting TV programs, we have replaced the infrared TV remote controller with a small wireless keyboard (Fig. 6). Considering that users of our system would be a family member or close couple, they would tend to have similar preferences in TV program. Therefore we place it in the R3 category where the system will play a soft chime for minimal interruption.

The system architecture of the InPhase system is described in Fig 7. In this example, House A and B each have a PC with middleware software running on Ruby which controls the Phidgets and USB parallel servers. These two remote PC’s are connected to each other via the Internet. When an action occurs on one of the PC’s, it is sent to the opposing PC’s server application via a separate and independent web server.

As seen in Fig. 4 and 10, the sofa is wired with three separate pressure sensors placed under the cushion. These sensors are connected to a computer via a Phidgets Interface Kit. To determine if people are present in a room, a motion sensor is placed in the corner of a room and a USB-to-parallel converter connects the motion sensor to a PC running a ParallelServer. For the door and the refrigerator door, a magnetic reed switch is used and connects to another USB-to-parallel converter to the same PC above.

All interfaces have accompanying server software components which are abstracted at the middleware layer to allow for a flexible command structure to help in supporting future devices and allow for a simpler Ruby interface. The servers each consist of a user interface component and a TCP networking component connected independently to a Ruby layer which handles communications as well as command/control infrastructure back to each server component.



**Figure 4. Sensor placement in sofa.**



Figure 5. Sensor placement on refrigerator door – Lab B.



Figure 6. Sensor placement on TV IR port.

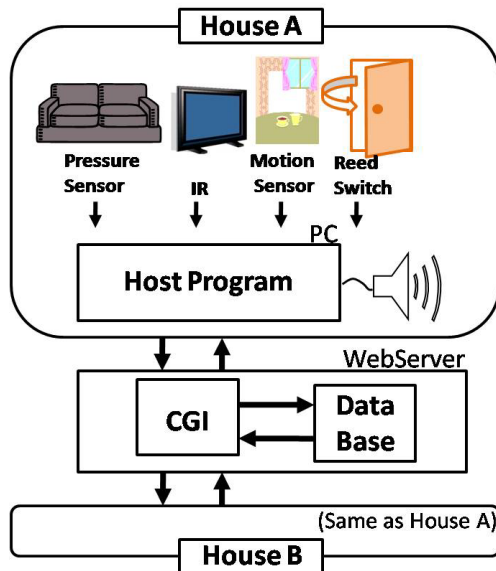

Figure 7. Overview of the InPhase components.

## LABORATORY FIELD TEST

To determine the effectiveness of the system, we conducted the following laboratory based field test. There were a total of 11 people (8 people from Lab A and 3 people from Lab B) who participated in the field test. In some instances, members from Lab A would also work in Lab B and thus had an average of 3-5 students working in each lab. The two male participants and 9 female participants were between the ages of 22 and 32 under the same laboratory. For events with significantly different frequencies, we selected an entrance door and refrigerator door. For a two month trial, we set our system up in two laboratory rooms separated by a distance of 70 m on the same university campus. We installed magnetic reed switches on the entrance door and the refrigerator door in each room. During the test, the participants were asked to go about their normal daily lives. We logged the opening and closing events for both doors and refrigerators.

During the field test, there were an average of 59 and 73 entrance door events, and 5.5 and 9.6 refrigerator door events per day, from each room, respectively. This resulted in an average of 1.8 coincidences per day for the entrance doors and no coincidences for the refrigerator. The refrigerator door was used far less frequently than the entrance door, and thus failed to initiate coincidences. However, if the system extended the duration of opening the refrigerator door by 10 seconds, as explained in Fig. 3, the number of coincidences increases to about 0.2 per day. From this data, we were able to confirm that the mapping for these doors in Fig. 2 were generally correct.

	Lab A	Lab B	Coincidences
Door	59 per day	73	1.8
Refrigerator door	5.5	9.6	0.0

Table 1. Usage frequency and coincidences between two laboratory field locations.

Following this test, participants commented about feeling both happy and excited when they heard the chime signifying a coincidence. This led to participants starting conversations (e.g., who is currently working, what are they doing, etc.). Furthermore, from the middle of field test, the participants even started posting messages to Twitter [1] as shown in Fig. 8. While one person may have triggered the coincidence, in a group setting, the coincidence notification is experienced (heard) by the entire group. Therefore, many (non-triggering) participants also commented that they wanted to know who they were having a coincidence with. Thus, both triggering and non-triggering participants said that they decided to initiate communication using chat or phone depending on who they might be having the coincidence with.

Other participants also mentioned that they wanted to have more coincidences. While we initially assumed that the

frequency of coincidences at 1-2 times per day was the frequency where the user felt most happy, depending on the event a user adjustable frequency might be more accommodating.



Figure 8. Twitter postings of events.

**HOME FIELD TEST**

To determine the effectiveness of the system in everyday family life, we conducted the following field test in an actual home during a three month trial.

**The aim of field test**

The aim is to determine “frequency of coincidences” and to investigate the following:

- Did the InPhase system enhance intimacy, closeness and potentially prompt other forms of communication?
- Did the system reduce the annoyance and privacy concern compared to prior systems?

**How the field tests were conducted**

The families were comprised of the following participants:

- Family A - grandfather (62 years old), grandmother (60 years old), daughter (26 years old)
- Family B - mother (32 years old), father (32 years old), daughter (3 years old)

Family B’s mother is the daughter of family A’s grandparents.

All participants are rarely at home during the day. The daughter of family A was one of the authors of this paper and was conducting the field test and therefore not part of the dataset. The daughter of family B also goes to a nursery school during the day.

The two families live in the same city separated by a distance of 30 minutes by car. They meet about once every two weeks (usually at family A’s residence for half-a-day)

and contact each other by e-mail and phone about 1-2 times a week.

We installed the InPhase system in their homes and asked the participants to keep a daily journal to provide feedback on the system. Separately, we recorded detailed system logs of the field test.

In this field test, we focused on coincidences in the living rooms where the family gathered. Among the events in the living rooms, we selected four actions (door open/close, sit on sofa, open/close window, watch TV channel) which we initially classified in the R2 section – an area of optimal user coincidences per Fig. 2, and set up sensors appropriately. In placing the sensors in an actual home, the implementation of wireless sensors using Xbee [2] eliminated the need for cumbersome wires. Fig. 9, 10 and 11 show the state of the installed sensors.

Family A used the living room door when they left for work and when returning home. They used the window when they hung out and took in the laundry every morning and evening. The sofa was mainly used to watch TV after dinner. They also watched TV in the morning and/or nights without sitting on the sofa.

Family B also used the living room door when they went to work and came home. They opened and closed the window in order to let fresh air into the room. The sofa was used when reading a book or watching TV at night. They also watched TV in evening or night without sitting on the sofa. They also recorded TV programs and watched them at different times.



Figure 9. Sensor placement on door – House A.



Figure 10. Sensor placement on sofa – House A.



Figure 11. Sensor placement on window – House A.

**OBSERVATIONS**

This section presents findings from the captured log data, participant’s journal and post interview.

*Analysis of log data*

	House A	House B	Coincidences
Door	2.8 per day	1.6	0.7
Sofa	11.3	12.5	1.0
Window	11.1	0.3	0.2
TV	2.9	2.0	0.14

Table 2. Usage frequency and coincidences between two home field locations.

Table 2 shows the frequency of coincidences per day and the average number of daily use of the door, sofa, window and TV during field test period.

From Table 2, one can infer that the frequency of coincidences for both the window and watching the TV channel were significantly lower than 1-2 times per day originally predicted. Therefore, we believe that these

events were probably not appropriately similar. For example, Family A often opened and closed the window to do the laundry. However Family B hardly ever opened the window for any reason. As for the television, Family A didn’t change the channel frequently because they usually watched a particular show until the end. Family B usually taped their show and watched the time-shifted video more often than they watched live TV. As a result, it was reasoned that the coincidences of watching television were not quite a match. We believe frequency of event and coincidences were rare due to completely different TV viewing habits as well as the time shifting nature of taping TV shows and watching them at their non-programmed time.

The frequency of coincidences with the door and sofa were within the 1-2 times per day range. We considered the frequency of coincidences as appropriate. Fig. 12 and 13 show the frequency of usage and coincidences in each house. Furthermore, the frequency of door usage is seen to decrease over the experimental period in Fig. 12. We believe that this was due to several reasons. For example, early in the field test – the beginning of April – the weather was cold so the family members often opened and closed the door each time they went into another room where one was heated and the other was not. However, when the weather warmed, both families kept the door open. Therefore, the frequency of door usage decreases over the field test period as the seasons changed.

From Fig. 13 it can be seen that family A used the sofa in a regular manner. On the other hand, family B had a higher sofa usage frequency early in the experiment which normalized to regular usage after some time. It was learned that the daughter repeatedly used the sofa as toy early in the experiment because she was very interested in hearing the chime tone when she sat down on the sofa.

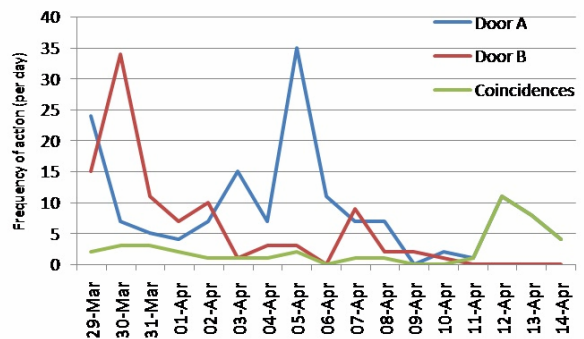

Figure12. The frequency of door usage and coincidences in each house.

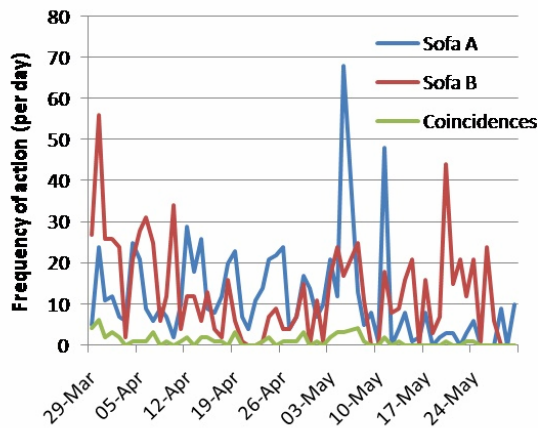

Figure13. The frequency of sofa usage and coincidences in each house.

### JOURNAL ENTRIES AND INTERVIEW RESULTS

Journal entry review and interviews of the field test subjects were conducted independently. We asked the participants to keep a daily journal about their experiences using the system and their feelings as well as any thoughts that occurred to them regardless of how irrelevant they thought it might be. After the field test, we went through the journal entries and asked the participants to answer questions which focused on addressing the aim of the field test. Specifically, whether the system enhanced intimacy and closeness as well as whether the system reduced annoyance and privacy concerns versus other forms of communication. Furthermore, we also asked the participants to elaborate on any entries that were interesting to see what prompted the participant's account and what/why they felt that way. The data obtained which is specific to this field test are presented here.

#### Family A - Grandfather

In one of the grandfather's journal entries, there was an account where the grandmother was sitting on the sofa and there was a tone sound that played many times in a row. Concerned, the grandfather called his daughter and asked her what happened. His daughter said that his granddaughter was having fun triggering the chime by repeatedly sitting on/off the sofa. Since then, the grandfather thought that his granddaughter was playing on the sofa whenever he sat down on the sofa and heard the chime sound. He was pleased to hear the chime. Furthermore, whenever he heard the chime sound of the sofa, he wondered what his granddaughter was doing then and/or started talking to his wife about his granddaughter. Conversely, when he sat on the sofa and didn't hear the chime sound, he started wondering about his grandchild like "Where is she going today?" or "Did she already go to the bed?" Similarly, when he heard the chime sound of the door late at night, he wondered "What's going on? Why

isn't my granddaughter asleep yet?" At times, he also worried that the chime sound might cause the grandchild to wake up.

#### Family A - Grandmother

In the interview, the grandmother mentioned that when she opened the window to hang the laundry in the morning and heard the chime sound, she wondered if they were waking up now. The grandmother also said that she imagined her daughter's activities, "I wonder where they are leaving to?" when she heard the chime.

She also described the following in her journal - "I heard a sound when I was sitting on the sofa during the day. I guess my son-in-law is off today and at home because my granddaughter would be at a nursery school during that time."

#### Family B - Mother (child of family A grandparents)

The mother had the following journal entries - "My child - 3 years old felt the system was fun because it played a chime when she sat on the sofa or opened the door. She was playing with it like a toy. Therefore, she had fun when it played the chime sound - once when she used the door and many times when sitting on the sofa - she definitely had a lot of fun. The mother also described how she called the grandparents to report the daughter's behavior.

The mother also described how she thought more about her parents when she heard the chime sound. This was especially true when she opened and closed the window and heard the chime sound - "My mother must be doing the laundry" or "It's so cold, I can't believe they are opening the window!" or "She is awake early!" On the other hand, when there wasn't a coincidence in a particular day, she became a little worried about her parents such as "What's up today?" In the interview, she also mentioned - "I know my parents life cycle, so I purposely opened the door or window in order to manufacture a chime sound."

#### Family B - Father

In the interview, the father said "I was happy to hear a chime sound. However when it played a chime sound every time I opened the door, I thought of my in-law's and even felt a little resistance in continually transmitting my actions."

### DISCUSSION

We discuss the results of the field test and how they matched the original predictions.

#### Did the InPhase system enhance intimacy, closeness and potentially prompt other forms of communication?

From the mother and grandparents journal, we found that they felt the presence of the other family and thought about their behavior and state through the coincidence notification. The InPhase system also prompted communication amongst

the families. Moreover it prompted and enhanced existing forms of communication such as email and phone.

As we can see from the mother and grandfathers journal entries, the sofa was used not only on a daily basis but also actively utilized as a means of communication between grandparents and granddaughter. While the child felt the system was like a toy, the grandparents felt the presence of their grandchild whenever the system played the chime sound, indicating coincidences of sofa usage. Coincidentally, when the father and not the child used the sofa, the grandparents, even after knowing the facts (after the test) still said that they felt the presence of their grandchild when they heard the chime sound.

From the interview with mother, we found that she intentionally created coincidences by keeping the window or door open. She wanted to transmit her behavior to her parents or to feel secure knowing her parents were well – in other words, another means to communicate between her parents and her child.

### **Did the system reduce the annoyance and privacy concern compared to prior systems?**

According to log data (after 4/11 in figures 12 & 13) and the post test interview, both families during the field test often kept their doors and windows open. In this field test, we decided to sound a chime if the state of each event action was same on both ends. Whereby, the system indicated coincidences even if there were no people near the other door or window.

Consequently, in certain situations where one window or door was left opened, the actions were continually transmitted to the remote party. One participant, the father, felt some concern towards privacy and annoyance similar to that of prior systems. From the interview, the father had a positive impression to hear the sound signifying coincidence, yet he felt concerned in conditions where his actions were continually transmitted.

In order to solve this problem, we need to reconsider the settings for events. For example, in this field test we indicated coincidences when the state of the door was the same. Therefore, we feel that a more effective method is to notify only when the action of opening the door was same or to confirm when there are people actually near both doors. With these alternative methods it is possible to avoid transmitting actions continually and can reduce the annoyance and privacy concerns. On the other hand, none of the participants felt any annoyance towards the sound indicating a sofa's coincidences. We speculate they didn't feel hassled because the sofa sounded the chime only when both families were relaxing on the sofa.

While prior systems were based on the unconditional and complete conveyance of the remote parties activities, our research focuses on conveying only the coincidental, natural, day-to-day interactions. Aside from the situation

where a window or door was left open, where our system behaved briefly like prior systems, there was no other form of complaints towards privacy and/or annoyance.

### **Other**

The participants mentioned that if both door and window were kept open, they didn't know which event triggered the coincidence and therefore the chime (the receiver). To address this, we considered changing the sound depending on the type of event. Further, we also considered mechanisms to adjust duration time and only chime when people are near either the door or window.

Furthermore, according to the laboratory field test interviews, we found that an important factor in deciding whether a person wanted to communicate depended on who they might be having a coincidence with. Meanwhile, from the interviews of the family field test, the grandparents felt that the presence of their grandchild via the chime sound, even if father actually used the sofa, was the overriding interest. In these cases, we felt it was more important to stir the imagination than to indicate who the coincidences were occurring with.

### **RELATED WORK**

Many research projects have explored the issue of remote awareness.

Digital Family Portrait [19] is one of several electronic picture frames that can display the daily activities of family members who live far from their families. For example, it could be used to display the daily activities of an elderly person who lives far from his family. This research's aim was mainly to support family members living apart. Presence Displays [9] are physical peripheral awareness displays of online presence of close friends or family. Feather, Scent, and Shaker [22] are elegant design based systems that enable long-distance couples to communicate. MeetingPot [21] is a device that can inform people of a coffee break, in a common office area, by using the aroma of coffee. Physical awareness proxies [17] and [12] convey a remote user's (mainly co-workers or laboratory members) availability, using a tangible interface. Tangible Bits [14] enables users to be aware of background bits at the periphery of human perception using ambient display media such as light, sound, airflow, and water movement in an augmented space. Building Flexible Displays for Awareness and Interaction [11] described a set of flexible ambient devices that can be connected to any available information source and that provide a simple means for people to move from awareness into interaction. Virtually Living Together [25] described presence by representing the interaction of people with everyday objects such as stones, chairs and portraits. VIO [16] is low bandwidth software application for communicating intimacy for couples in long-distance relationships by displaying a bright red circle – when clicked - which fades over time. The application also allows for an easy method of showing the



remote partners state by moving the mouse over the application.

In these examples, the devices were designed for asymmetric, one-way communication, which separate the user sensing portion from the information presenting function. These systems unconditionally convey the remote parties' activities and information. Our system also separates the user sensing portion from the information presenting function, however our research focuses on conveying only the coincidental natural day-to-day interactions

Family Planter [15] is a pair of artificial flowerpots with sensors, lights and actuators that indicate the proximity of people in houses that are located far apart. Peek-A-Drawer [18] provides virtual shared drawers across distant locations. LumiTouch [5] is a pair of photo frames, and ComSlipper [7] is a pair of slippers to indicate the activities of a partner who lives far away. ComTouch [6] is a device that augments remote voice communication using touch by converting hand pressure into vibrations of differing intensity and conveying that between users in real-time. FeelLight [23] is a communication device where a button is connected to a multi-colored light source. The signal of whether the button is pressed or not is transmitted to the other side of the line where there is a similar light source. The color of both light sources is synchronized with each other. Lover's Cup [8] is a communication tool for drinking-together interaction between long-distance couples. The bed [10] is a bed environment that creates the virtual existence of a person (who lives far away) in a bed.

These investigations are based on the unconditional conveyance of remote parties' activities through devices for symmetric, bi-directional (two-way) communication that combine both the sensing of user action or situation with a correspondingly similar information presentation. Our system notifies of coincidences by playing a sound when similar actions of two people in different locations happen simultaneously and not the initiated action of one party.

inTouch [13] is a pair of communication devices with cylindrical rollers that rotate synchronously. RobotPHONE [20] is a Robotic User Interface (RUI) that uses robots as physical avatars for interpersonal communication. Using RobotPHONE, users in remote locations can communicate shapes and motion with each other. SyncDecor [26] are pairs of traditional appliances remotely synchronized to provide awareness about their partners.

These investigations try to reflect a person's actions directly onto remote devices. Our research focuses on conveying only the coincidental natural day-to-day interactions, thus reducing annoyance of the remote party as well as maintaining their privacy.

There are several research projects that address awareness and communication in the domestic environment. SPARCS [4] is a system which encourages frequent sharing of photos

and calendar information with ones extended family. ASTRA [18] is a lightweight messaging system that provides awareness of closely related people through messages based on pictures and handwritten messages. The approach and measurement methods proposed here may serve as reference to enhance the measurement of connectedness. Tee, et al. [24] is a study done to explain the how people use existing technologies to communicate with their extended family. The study provided information on sharing habits, the design implications of remote systems and the perceived value of interaction as well as obligation. The Casablanca project [13] explored how media space concepts could be incorporated into households and family life.

These investigations are based on transmitting some kind of visual information (i.e., pictures, handwritten messages) or the habits of sending such information. Our research focuses on conveying underived and innate interactions, and thus being natural and familiar to the receiving party.

Martjin, et al. [27] is a study that discusses the acceptability of notification methods in a living room laboratory. The study investigates the acceptability and ability to improve such acceptability of messages based on their urgency. The main difference to our research would be the difference in the type of notification – where one is sending “urgent” messages versus natural interaction based messages that one would receive if they were in the same room together.

## CONCLUSION

By investigating the coincidences that occur in the daily lives of people living apart, we describe a system that notifies pairs of users of similar events that happen nearly simultaneously between them. We conducted a two month field test of the system in our laboratory which sensed the opening and closing of entrance and refrigerator doors, determined coincidences and notified the users. The participants of the test commented about feeling both happy and excited when they were notified of such coincidences. Furthermore, we implemented a second field test of the system in actual homes using wireless sensors. In placing the unobtrusive wireless sensors, we conducted a three month field test. We found that participant families felt the presence of other family members and thought about, imagined or even confirmed the habits of others by intentionally triggering the coincidence notification. Our field test was small in scale and consisted of one of the author's family, so the participants may have been positive towards the system. Nevertheless, our findings managed to deliver results and hope it will help others to enhance their systems to better support remote communication between people living apart.

## ACKNOWLEDGMENTS

This work was partially supported by the Ministry of Education, Science, Sports and Culture (MEXT), Grant-in-

Aid for Japan Society for the Promotion of Science (JSPS) Fellows.

## REFERENCES

1. <http://twitter.com/>
2. <http://www.digi.com/products/wireless/zigbee-mesh/xbee-series2-module.jsp>
3. Asch, S. Forming impressions of personality. *Journal of Abnormal and Social Psychology*, 41, 1946, 258-290.
4. Brush, A. B., Inkpen, K. M., and Tee, K. 2008. SPARCS: exploring sharing suggestions to enhance family connectedness. In *Proceedings of the ACM 2008 Conference on Computer Supported Cooperative Work (San Diego, CA, USA, November 08 - 12, 2008)*. CSCW '08. ACM, New York, NY, 629-638.
5. Chang, A., Resner, B., Loerner, B., Wang, X. and Ishii, J. LumiTouch: An emotional communication device. *Ext. Abstracts CHI 2001*, ACM Press (2001), 313-314.
6. Chang, A., O'Modhrain, M.S., Jacob, R.J.K, Gunther, E. and Ishii, H. ComTouch: Design of a vibrotactile communication device. In *Proc. of Symposium on Designing Interactive Systems, 2002*, pp. 312-320.
7. Chen, C.-Y., Forlizzi, J. and Jennings, P. ComSlipper: An expressive design to support awareness and availability. *Ext. Abstracts CHI 2006*, ACM Press (2006), 369-380.
8. Chung, H., Lee, C.-H. J. and Selker, T. Lover's Cups: Drinking interfaces as new communication channels. *Ext. Abstracts CHI 2006*, ACM Press (2006), 375-480.
9. Dey, A. K. and de Guzman, E.: From awareness to connectedness: the design and deployment of presence displays, CHI '06: Proceedings of the SIGCHI conference on Human Factors in computing systems, New York, NY, USA, ACM, pp.899.908 (2006).
10. Dodge, C. The bed: A medium for intimate communication. *Ext. Abstracts CHI 1997*: ACM Press (1997), 371-372.
11. Elliot, K. and Greenberg, S. Building Flexible Displays for Awareness and Interaction. *Video Proceedings and Proceedings Supplement of the UBICOMP 2004*.
12. Greenberg, S. and Kuzuoka, H. Using Digital but Physical Surrogates to Mediate Awareness, Communication and Privacy in Media Spaces. *Personal Technologies*, 4(1), January 2000, 182-198.
13. Hindus, D., Mainwaring, S. D., Leduc, N., Hagstrom, A. E., and Bayley, O. Casablanca: designing social communication devices for the home. In *Proc. CHI 2001*. ACM Press (2001), 325-332.
14. Ishii, H. and Ullmer, B. 1997. Tangible bits: towards seamless interfaces between people, bits and atoms. In *Proc. CHI 1997*. ACM Press (1997), 234-241.
15. Itoh, Y. Miyajima, A. and Watanabe, T. "TSUNAGARI" communication: Fostering a feeling of connection between family members. *Ext Abstracts CHI 2002*, ACM Press (2002), 810-811.
16. Kaye, J. I just clicked to say I love you: rich evaluations of minimal communication. *Ext. Abstracts CHI 2006*, ACM Press (2006), 363-368.
17. Kuzuoka, H. and Greenberg, S. Mediating awareness and communication through digital but physical surrogates. *Ext. Abstracts CHI 1999*, ACM Press (1999), 11-12.
18. Romero, N., Markopoulos, P., Baren, J., Ruyter, B., Ijsselsteijn, W., and Farshchian, B. 2007. Connecting the family with awareness systems. *Personal Ubiquitous Comput.* 11, 4 (Apr. 2007), 299-312.
19. Rowan, J. and Mynatt, E.D. Digital Family Portrait Field trial: Support for aging in place. *Ext. Abstracts CHI 2005*, ACM Press (2005), 521-530.
20. Sekiguchi, D., Inami, M., and Tachi, S. RobotPHONE: RUI for interpersonal communication. *Ext. Abstracts CHI 2001*. ACM Press (2001), 277-278.
21. Siio, I., Rowan, J., Mima, N. and Mynatt, E. Digital Decor: Augmented Everyday Things. In *Graphics Interface 2003*, PP. 155-166, June 11-13 2003.
22. Strong, R. and Gaver, W. Feather, Scent, and Shaker: Supporting simple intimacy. In *Proc. of CSCW 1996*, ACM Press (1996), 29-30.
23. Suzuki, K. and Hashimoto, S. Feellight: A communication device for distant nonverbal exchange. In *Proc. of the 2004 ACM SIGMM Workshop on Effective Telepresence*, (2004), 40-44.
24. Tee, K., Brush, A. B., Inkpen, K. M. Exploring communication and sharing between extended families. *International Journal of Human-Computer Studies*, 67, 2009, 128-138
25. Tollmar, K., Junstrand, S., and Torgny, O. Virtually living together. In *Proc. Designing Interactive Systems 2000*. ACM Press (200), 83-91.
26. Tsujita, H., Siio, I., and Tsukada, K. 2007. SyncDecor: appliances for sharing mutual awareness between lovers separated by distance. *Ext. Abstracts CHI 2007*, ACM Press (2007), 2699-2704.
27. Vastenburger, M. H., Keyson, D. V., and Ridder, H. Considerate home notification systems: A user study of acceptability of notifications in a living-room laboratory. *International Journal of Human-Computer Studies*, 67, 2009, 814-826